

item number	A (mm)	B (mm)	thickness of metal sheet (mm)
<b>NPS 62_ZNCR</b>	82	42	1,5
<b>NPS 125_ZNCR</b>	145	70	2,0
<b>NPS 250_ZNCR</b>	270	100	2,0
<b>NPS 62_F</b>	82	42	1,5
<b>NPS 125_F</b>	145	70	2,0
<b>NPS 250_F</b>	270	100	2,0

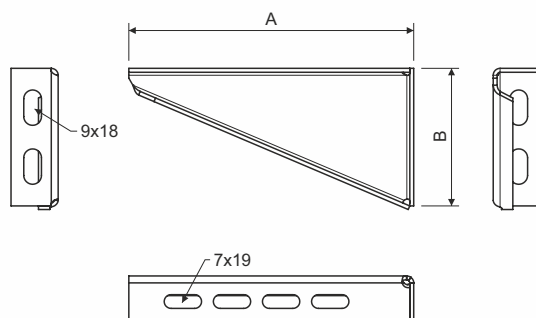

**product description:** The wall bracket is used as a supporting structure for fastening MARS cable trays to the wall.  
 Cable tray attaching to the wall support is carried out by bolts NSM 6X10. The bolt head is inside the cable tray to protect the cables.  
 A bolt with a GMT surface finish is used for a tray with an F surface finish.  
 The wall bracket is fastened to the wall using 2 pieces of Ø8 mm anchors (for NPS 62 it's only 1 anchor).



**surface finish:** ZNCR - bichromatic galvanised  
 F - Hot Dip Galvanized, zinc-layer 50 - 100 µm  
 EC - epoxy paint for indoor use - total paint, 60 µm

**sales amount:** á 1 pc

**meets the requirements:** EN 61537:02

**classification:** ČSN 73 0895 P 90-R  
 DIN 4102-12 E 90  
 STN 92 0205 PS 90

Fire classification is depend on the specific conditions of the cable tray, detailed in the catalog Systems with maintained functionality in fire.

Systems may be supplied with various surface finishes whereas the surface finish does not affect the determined maintained time of operability in fire.

**storage:** EN 60721-3-1